

Steel box for 4 or 6 module with electrical and/or multimedia system.

Painted White, Black or Grey.

Available with cable management (optional).

Beam in steel pipe 30x30 mm chromed.

Swivel castor with brake \varnothing 75 mm polypropylene support .

Available top finishes:

- MFC
- MFC FSC® (Available upon request)
- MFC 3D
- MDF PerfectSense
- Writable Laminate

Galvanized steel sheet metal
Flip top and rotation leg mechanism with release handles.

Cover in black polypropylene (PP).

Grey nylon linking device to join tabletops (optional).

Leg in steel pipe 40x40 mm.
Epoxy powder painting
White RAL 9010
Grey
Black RAL 9005.



20° rotation of the leg with vertical top.

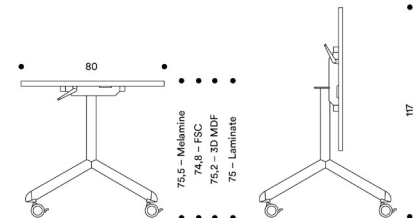
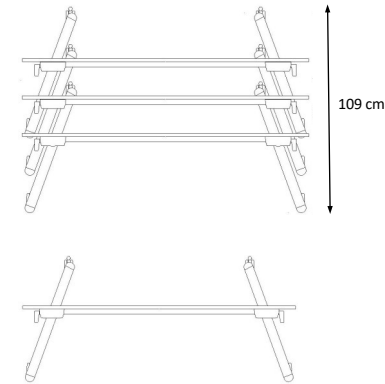

Available modesty panel finishes:
MFC
MFC 3D
MDF PerfectSense



Leg Finishes



Leg in steel pipe 40x40 mm.
Epoxy powder painting
White RAL 9010
Grey
Black RAL 9005.

Top Finishes

<p>MFC thk.25 mm edge in ABS thk.2 mm</p>	<p>WHITE U12 (FSC® thk.18 mm available upon request) GREY 0FP LIGHT OAK 0ON</p>
<p>MFC 3D thk.22 mm edge in ABS thk.1 mm</p>	<p>GREY OAK S075 HONEY OAK S073 WHITE OAK S074 NATURAL OAK ST37</p>
<p>MDF PerfectSense thk.22 mm edge in ABS thk.1 mm</p>	<p>BLACK U999 WHITE W1100 STONE GREY U727 GRAPHITE GREY U961</p>
<p>*Writable Laminate thk.20 mm edge in ABS thk.2 mm</p>	<p>WHITE 028</p>

*Available only for Socrate 160AR/ Electrical Boxes not available with this finishing.

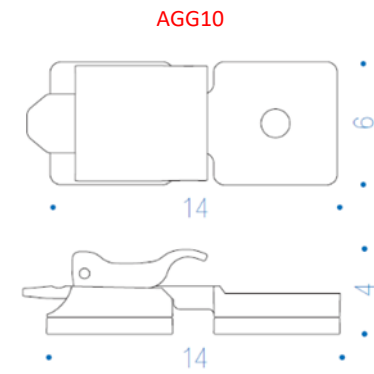

Grey nylon linking device to join tabletops.

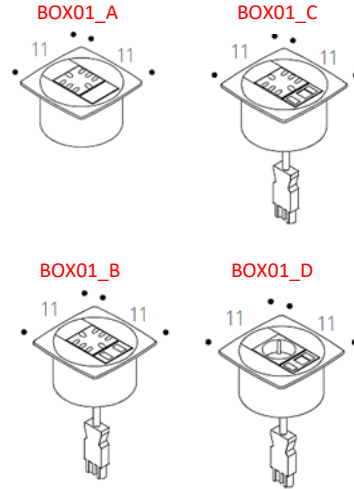

CAV_002
Connection cable between electrical modules 2 mt.
(H05VV-F 3G 1.5 mm² / GST18 - GST18).

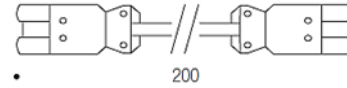

CAV_004
Electric cable 2 mt.
(H05VV-F 3G 1.5 mm² / GST18 - Male).

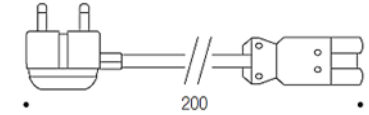

CAV_015
Power distributor with 3 poles.

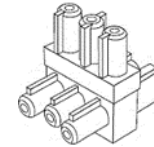

Single module in ABS with electrical and/or multimedia system or cable management.
Available colours Dark grey RAL 7024 and White RAL 9016.

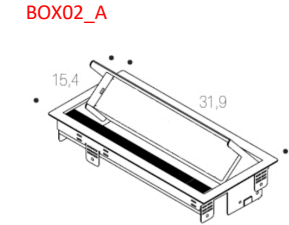
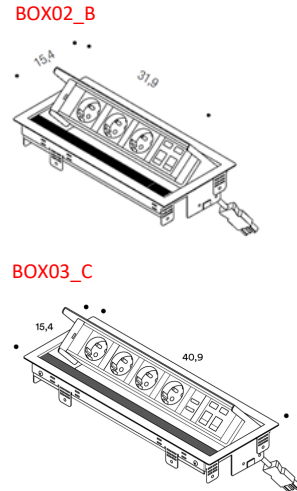

Steel box for 4 or 6 module with electrical and/or multimedia system.
Available colours Black RAL 9017, Grey RAL 9006 and White RAL 9016.

Painted steel cable management resealable module.
Available colours Black RAL 9017, Grey RAL 9006 and White RAL 9016.

National and International Sockets



Multimedia Accessories

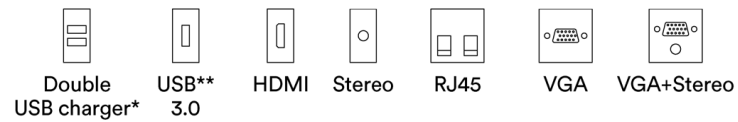

* USB charger only charger
** USB 3.0 only data

Shapes and tops dimensions

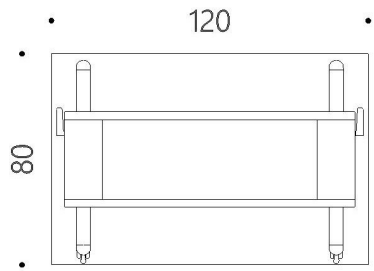

SOCRATE 120AR

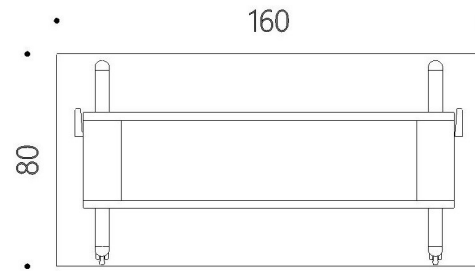

SOCRATE 160AR

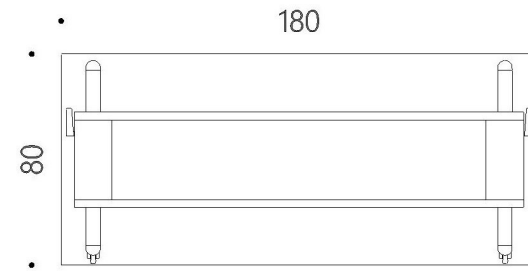

SOCRATE 180AR

PACKAGING

From suppliers certified who use responsibly sourced materials.

RECYCLING OF THE PRODUCT

Once decommissioned, avoid release into the environments. Recyclable product separating its components.

CLEANING

For the metal parts, we recommend to use only a damp cloth with alcohol and to dry everything very well after cleaning.
 For painted surfaces, please use only a damp cloth with water and neutral liquid detergent. Do not use solvents, trichloroethylene, acetone or ammonia.

WARRANTY

Our products are guaranteed for 5 years (full text of warranty on request). An improper use of the product precludes its warranty.

IMPROPER HANDLING

Not allowed: structural changes and/or tampering with the product.



The mark of responsible forestry



Compliance certificate in accordance with ANSI/BIFMA X5.5-2014.

*Products available upon request